

# **Saturn<sup>®</sup>**

**ST-FP7071**

**FOOD PROCESSOR**

RU

! "Saturn".

)

1,5

1,5



14

-2

1  
2  
3  
4  
5  
6  
7  
8

9  
10  
11  
12  
13  
14  
15

16  
17  
18  
19  
20  
21  
22  
23

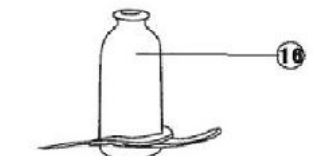
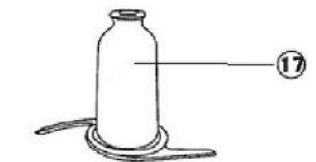
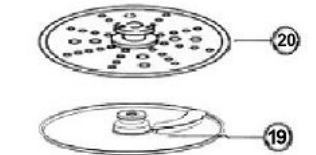
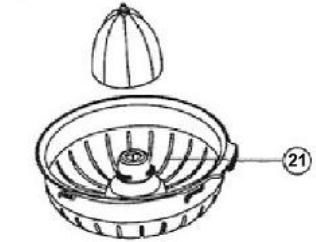
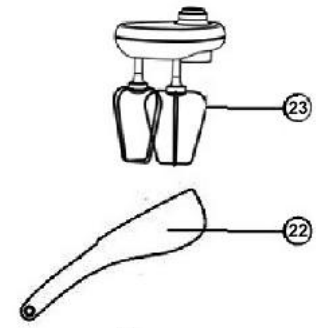
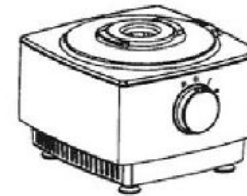
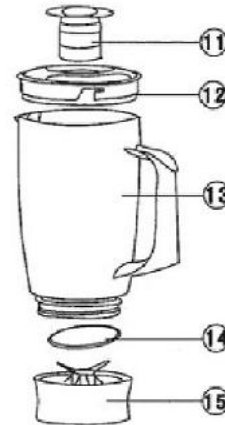
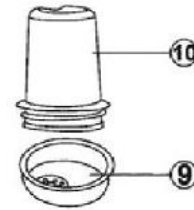
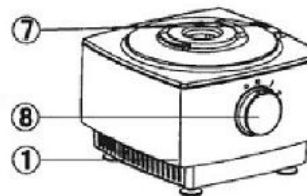
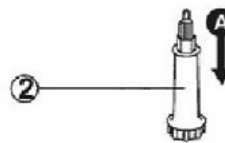
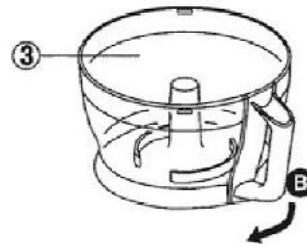
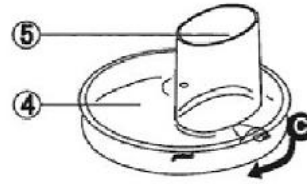

		2 1-2 2	500 500	30
	( )	2	500 280	60
/	/	1-2		60
	( )	1-2	1200	60
		1		30
/		2		30

4.  
[4]  
5.

6.

1.  
(14)

2.  
3.

4.

5.

6.

7.

1.

[1]. [2]

2.

[3]

3.

( )

( )

(15)

( )



16/

17

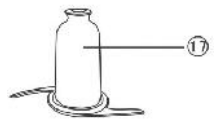

17

30-60

1,2 -

1.

2.

1.

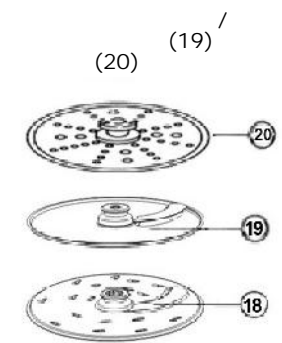

(20)

(19)

20

19

18

30-60

(18),

2.

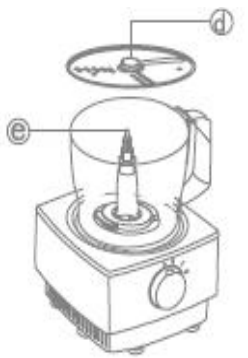

- 1.
- 2.
- 3.
- 4.

(d).

(.)

5.

(f).



(g).

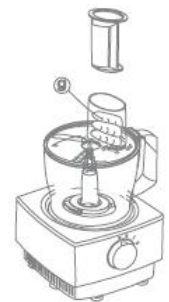

(21).

(

).

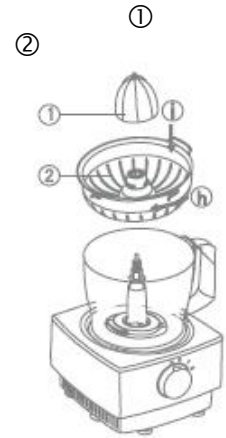

- 1.
- 2.
- 3.
- 4.

(h).

(i).

(10)

- (1)
- (2)
- (3)
- (4)

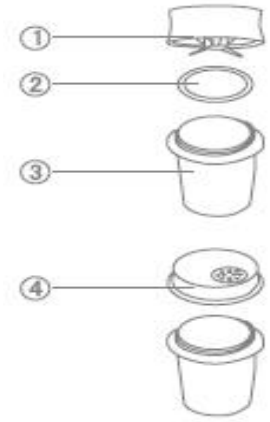

- 5.
- 6.
- 7.

(j).

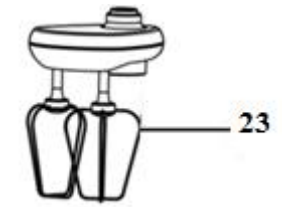

30-60

MAX.

- 1.
- 2.
- 3.
- 4.

1.

2.

3.



1  
1

- 2

» «

1.

2.

3.



"Saturn".

5.

1  
2  
3  
4  
5  
6  
7  
8

(  
)

9  
10  
11

1,5

12  
13  
14  
15

1,5

800  
:220-240  
50  
: 3,64

16  
17  
18  
19  
20  
21  
22  
23

1  
1  
1  
1  
1  
1  
1  
1  
1  
1  
1



14

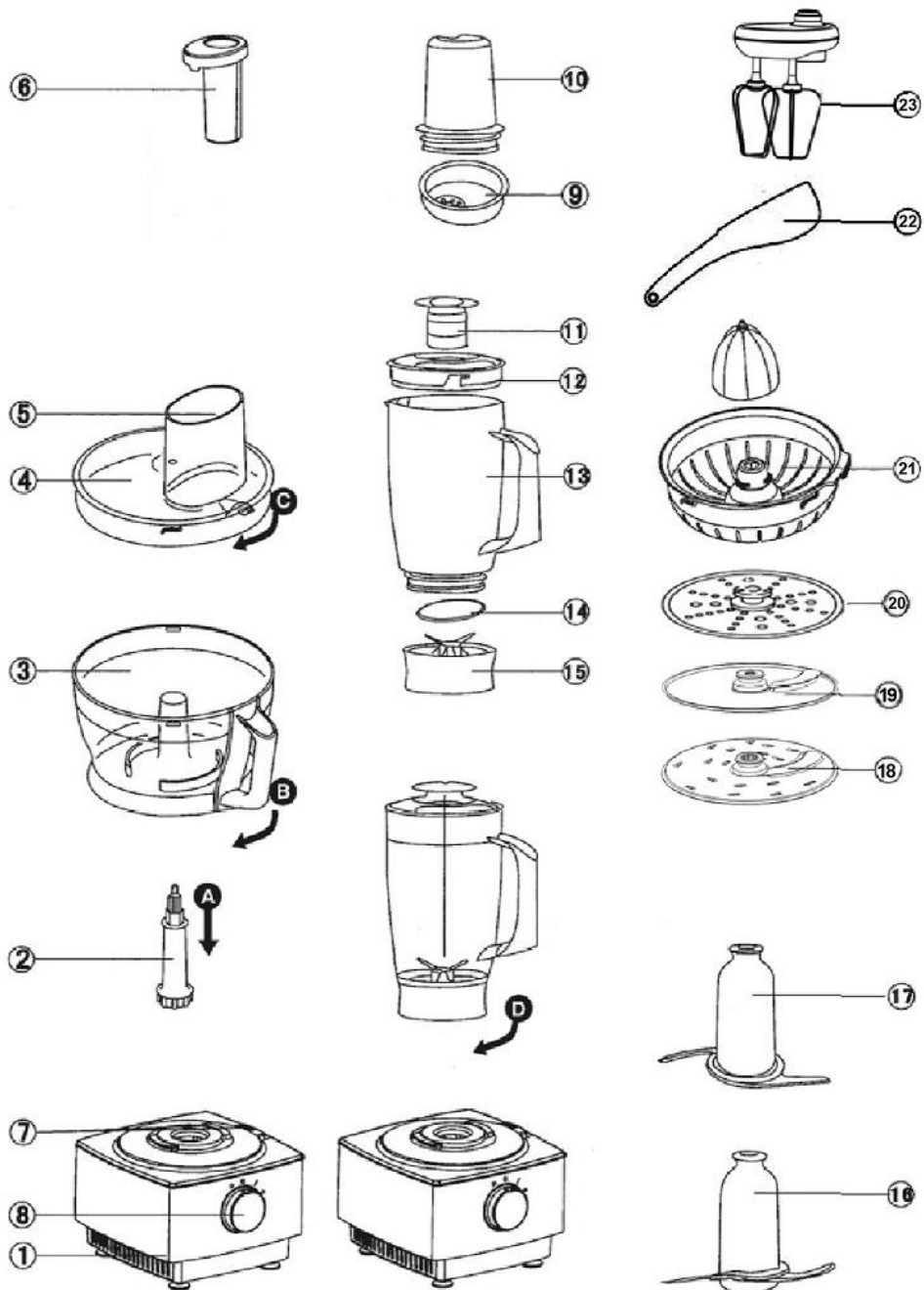

18

		2	500	30
		1-2	500	
		2		
		2	500	60
			280	
		1-2		60
		1-2	1200	60
		1		30
		2		30

1. [1] [2]
2. [3]
- 3.
4. [4]

19

- 5.
- 6.
- 7.
- 8.
- 9.
- 10.
- 11.
- 12.
- 13.
- 14.
- 15.
- 16.
- 17.
- 18.
- 19.
- 20.
- 21.
- 22.
- 23.

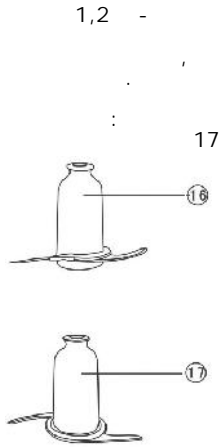

16/

2. 30-60  
 (18), (19) / (20)

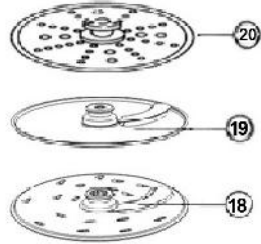

1.  
 2.

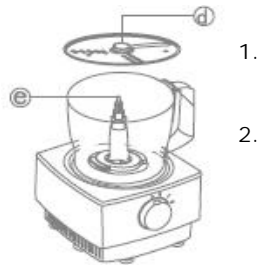

(d),

20

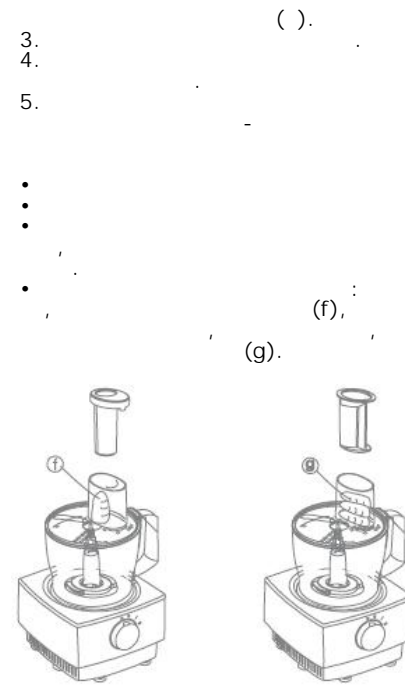

(21),

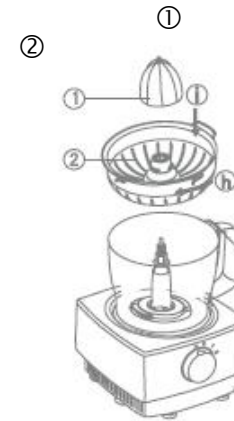

1.  
 2.

21

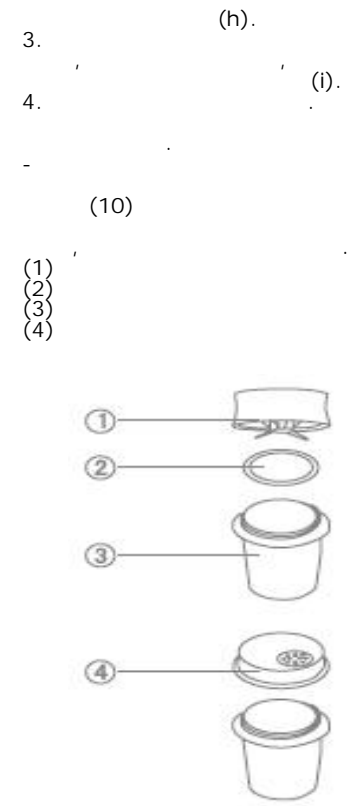

1.  
 2.  
 3.

30-60