



EN ■ Espresso Machine

READ CAREFULLY AND STORE FOR FUTURE USE.

- This appliance may be used by children 8 years of age and older and by persons with physical or mental impairments or by inexperienced persons, if they are properly supervised or have been informed about how to use the product in a safe manner and understand the potential dangers.
- Children must not play with the appliance. Cleaning and maintenance performed by the user must not be performed by unsupervised children.
- Before connecting the appliance to a power socket, check that the rated voltage on its rating label matches the electrical voltage in the power socket.
- Connect the appliance only to a properly grounded socket. For safety reasons, we do not recommend using multi-socket adapters or extension cords.
- This appliance is designed for household use only. It is not intended for use in locations such as:
 - staff kitchens in stores, offices and other workplaces;
 - hotel or motel rooms and other living areas;
 - agricultural farms;
 - bed and breakfast establishments.
- Do not place the appliance on window sills, kitchen sink drainboards or unstable surfaces. Always place it on a stable, even and dry surface.
- Do not place the appliance on or near an electrical or gas stove, or in the vicinity of an open flame.
- Never use the appliance in the near vicinity of a bath, shower or swimming pool.
- Use the appliance only for the purposes for which it was designed.
- Only use the appliance with the original accessories that came with it.
- To ensure sufficient air circulation, free space of at least 15 cm must be maintained around and above the appliance when it is running.
- Only use the top surface of the appliance for warming cups. Do not use it as a place for placing items.
- Fill the water tank with clean cold water. Do not pour hot water or other liquids into it or place any items inside it.
- Before turning on the appliance, check that:
 - the drip tray together with the grate is installed in position;
 - the water tank is filled with a sufficient amount of water and is properly installed in position. The water level must not exceed the water level mark.

- Before you begin brewing coffee, check that the portafilter is properly attached to the brew head. Pressure is created in the portafilter during the coffee steaming process, so do not move it while it is running. Otherwise, this could result in a dangerous situation.

 **Attention:**

Incorrect use may lead to injuries.

- When operating the appliance, be especially careful to avoid scalding by hot water or steam.
- Regularly inspect the water level in the water tank when using the appliance. When the water level falls below the minimum water level mark, add water. Before adding water, first turn the appliance off and disconnect it from the power socket.
- To protect the pump from damage, the appliance is equipped with a built-in thermal fuse that will disengage it when it runs empty. In the event that such a situation occurs, disconnect the power cord from the power socket and allow the appliance to cool down for at least 30 minutes. Then you may continue using it.
- Accessible surfaces of the appliance are hot during its use and afterwards as a result of residual heat. Do not touch hot surfaces.
- Always turn off the appliance and disconnect it from the power socket when not using it, when leaving it without supervision, before disassembling or assembling it, before filling up the water tank, and before moving or cleaning it. Allow the appliance to cool down before cleaning or moving it. Do not move the appliance with a coffee cup located on the drip tray grate or with cups located on the cup warming surface.
- Keep the appliance and its accessories in clean condition. Clean and maintain it according to the instructions in chapter Cleaning and maintenance. Never wash the appliance under running water or submerge it in water or another liquid.
- Make sure that the power cord does not come into contact with a hot surface and prevent the power plug from coming into contact with water.
- Disconnect the appliance from the power socket by pulling on the plug, never pulling on the power cord. Otherwise, this could damage the power cord or the socket.
- In the event that the power cord is damaged, have it repaired at a professional service centre to prevent causing a dangerous situation. It is forbidden to use the appliance if it has a damaged power cord.
- To avoid the danger of injury by electrical shock, do not repair the appliance yourself or make any adjustments to it. Have all repairs performed at an authorised service centre. By tampering with the appliance, you risk voiding your legal rights arising from unsatisfactory performance or quality warranty.

A

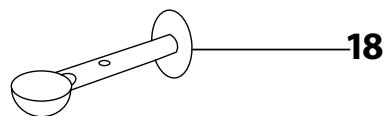
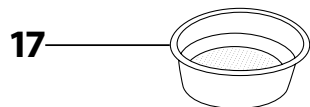
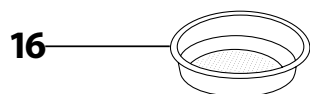
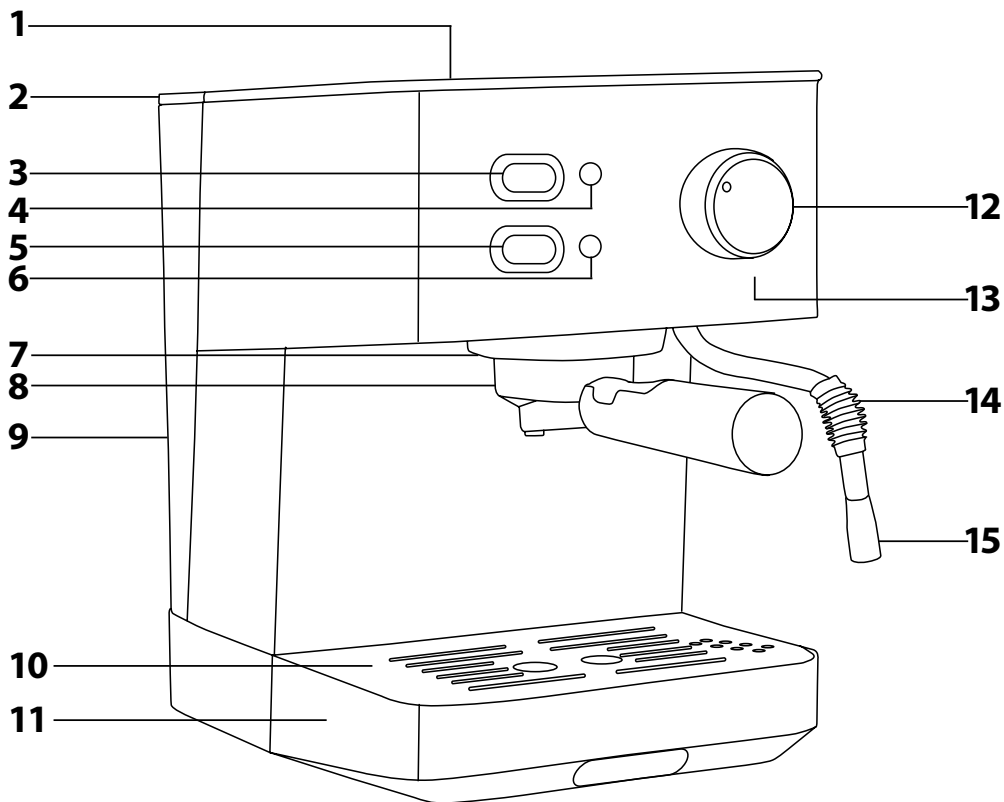

EN Espresso Machine

User's manual

- Prior to using this appliance, please read the user's manual thoroughly, even in cases, when one has already familiarised themselves with previous use of similar types of appliances. Only use the appliance in the manner described in this user's manual. Keep this user's manual in a safe place where it can be easily retrieved for future reference.
- We recommend saving the original cardboard box, packaging material, purchase receipt and responsibility statement of the vendor or warranty card for at least the duration of the legal liability for unsatisfactory performance or quality. In the event of transportation, we recommend that you pack the appliance in the original box from the manufacturer.

DESCRIPTION OF THE APPLIANCE

- | | |
|---|--|
| A1 Cup warming plate | A12 Selection knob, 3 options |
| A2 Tilt-down lid with handle | – brewed coffee ☐, stand-by mode ● and steam release ☞ |
| A3 ON/OFF button | A13 Boiler (not shown) |
| A4 Power indicator light | A14 Removable milk frothing sleeve |
| A5 Coffee brewing and steam release mode toggle button | A15 Swivel steam nozzle |
| A6 Coffee brewing or steam release water temperature indicator | A16 Stainless steel filter for 1 cup of coffee |
| A7 Brew head | A17 Stainless steel filter for 2 cups of coffee |
| A8 Portafilter with coffee spout | A18 Coffee measuring cup with tamper |
| A9 1.5-litre removable water tank | |
| A10 Removable grate | |
| A11 Removable drip tray | |

BEFORE FIRST USE OF THE APPLIANCE

1. Remove all packaging materials, protective film, promotional tags or labels from the appliance.
2. Install the appliance on an even, dry and clean surface. Take the water tank **A9** out of the appliance and rinse it out with clean water with the addition of a small amount of neutral dishwashing detergent. Then rinse it out thoroughly using clean water, dry it and put it back in its place.
3. Take out the removable drip tray **A11** with grate **A10**, wipe with a dampened textile, wipe dry and insert it back into the bottom part of the appliance.
4. Wash the portafilter **A8**, coffee measuring cup **A18** and the stainless steel filters **A16** and **A17** under clean running water with an addition of kitchen detergent. Then rinse with clean water and wipe dry.
5. Wipe the outer surface of the appliance with a lightly dampened cloth and then wipe it thoroughly dry.
6. Prior to brewing the first cup of coffee, run the appliance empty for approximately 60 seconds, i.e. with the water tank **A9** filled with water but without coffee tamped in the filter. This will clean out the inner components and the brew head **A7**. A sufficiently large container must be placed underneath the portafilter **A8** for the hot water to flow into. Instructions for starting the appliance are provided in chapter Operating the appliance.

OPERATING THE APPLIANCE

1. FILLING THE WATER TANK

- 1.1 Grasp the water tank **A9** by the handle **A2**. Lift it up and remove it from the rear part of the appliance.
- 1.2 Fill it up with cold water up to the maximum water mark, insert it back into the appliance and tilt down the lid with handle **A2**. The water tank **A9** must be securely seated in place in order for water to be pumped out of it into the boiler **A13**.



Note:

The water that you pour into the water tank **A9** should ideally be at room temperature (approximately 25 °C). Water that is too cold, could negatively affect the final taste of the coffee beverage.



Attention:

The water tank **A9** has a maximum capacity of 1.5 litres of water. Do not overfill it.
Never fill the water tank **A9** with warm water, hot water or sparkling water, or liquids such as, for example, milk.
Do not fill the water tank **A9** when it is inserted in the appliance. There is a danger of splashing the appliance or overfilling the water tank **A9**.

- 1.3 Do not leave any remaining water in the water tank **A9** for longer than one day. For brewing quality fresh coffee, it is necessary to use fresh water.

Otherwise, the resulting flavour of the coffee beverage may be negatively affected.

2. TURNING ON THE APPLIANCE

- 2.1 Connect the power cord plug to a power socket. Make sure that the water tank **A9** is filled with fresh water, that the drip tray **A11** and grate **A10** are installed in their place and that the knob **A12** is set to the stand-by mode position.
- 2.2 To turn on the appliance, press button **A3**. The power indicator **A4** will be lit.

3. PRE-HEATING THE APPLIANCE AND CUPS

- 3.1 Preparing a quality cup of espresso requires that the appliance, portafilter **A7**, filter **A16** or **A17**, and cups are preheated. This is done in the following way.
- 3.2 Place empty coffee cups upside down on to surface **A1** and allow them to warm up.
- 3.3 Make sure the button **A5** is in the pressed out position intended for coffee brewing. Select filter **A16** or **A17** and insert it into the portafilter **A8** so that it securely slides in along the entire perimeter. Insert the portafilter **A8** underneath the brew head **A7** so that the handle is pointing to the left. This position is marked with "INSERT" on the front panel of the appliance. To fasten the portafilter **A8** to the brew head **A7**, turn the handle to the right to the "LOCK" position.
- 3.4 Wait until the indicator **A6** lights up. Now the pre-heating process is finished.

4. BREWING COFFEE

- 4.1 Remove the portafilter **A8** from the appliance and place it on an even surface and pour the corresponding amount of ground coffee into the filter. The one-cup coffee filter **A16** is filled with a single level measuring cup **A18** of coffee. The two-cup coffee filter **A17** is filled with double the amount of coffee. One level measuring cup **A18** is equivalent to 7 g of ground coffee. Spread the coffee out evenly inside the filter and gently tamp it down with the flat end of the measuring cup **A18**.
- 4.2 Thoroughly clean ground coffee remains from the edges of the filter **A16** or **A17**. Insert the portafilter **A8** underneath the brew head **A7** so that the handle is pointing to the left. This position is marked with "INSERT" on the front panel of the appliance. To fasten the portafilter **A8** to the brew head **A7**, turn the handle to the right to the "LOCK" position.
- 4.3 Place one or two preheated cups underneath the portafilter **A8**. Make sure that the cups are located underneath the spout.
- 4.4 Set the knob **A12** to the coffee brewing position. Within a few moments, coffee will start flowing into the cups.



Note:

The indicator **A6** may turn off while the coffee is being extracted. This signals a decline in the water temperature in the boiler **A13**. The indicator **A6** will light up again as soon as the boiler **A13** heats the water up to the ideal coffee brewing temperature.

Once the required amount of coffee is in the cup, set the knob **A12** to the stand-by mode position. This completes the coffee extraction process. The extraction time for a cup of espresso should be between 20 and 30 seconds and the volume should be approximately 20 to 30 ml.

- 4.5 If you do not fill the filter with ground coffee, you may simply pour just hot water, for example for tea, hot chocolate, etc.
- 4.6 Before you start brewing another cup of coffee, first remove used coffee grounds, clean out the filter according to the instructions contained in chapter Maintenance and cleaning and pour out the water from the drip tray **A11**. When returning the drip tray **A11** to its place, push it all the way against the back wall of the appliance.



Attention:

The water contained in the drip tray **A11** is hot. When handling it, pay extra attention.
During operation, regularly check the water level in the water tank **A9** and make sure that it does not fall below the minimum water level mark.

5. USING THE NOZZLE TO FROTH MILK AND HEAT WATER

- 5.1 Prepare some cooled semi-skimmed or full-fat milk and the container in which you will froth the milk. During the milk frothing process, its volume expands, therefore fill the container to no more than 2/3 of its capacity.
- 5.2 Set the nozzle **A15** to such a position that the milk frothing process is comfortable.
- 5.3 Make sure that the knob **A12** is set to the stand-by mode position. Press button **A5** and wait until indicator **A6** lights up. This signals that the water in the boiler **A13** has reached the optimal steam generation temperature. This temperature is higher than for brewing coffee.

5.4 Place the container with milk underneath the nozzle **A15**. Submerge the nozzle **A15** just beneath the surface of the milk and set the knob **A12** to the steam release position. The nozzle **A15** will start releasing steam. Initially a small amount of hot water may be released. Hold the container slightly tilted to ensure that the nozzle **A15** remains constantly submerged just under the surface of the milk. The milk will circulate in the container, it will heat up and increase in volume. Milk froth will start to form on the surface of the milk. When the bottom of the container heats up so that it is hot to touch, stop the milk frothing by turning the knob **A12** to the stand-by mode position. When steam stops being created, remove the container. Using a swirling motion, whip the froth into the heated milk.



Attention:

The nozzle **A15** must remain submerged during the entire frothing process. Otherwise hot milk may splash out.

5.5 Pour the frothed milk into freshly brewed coffee and use a spoon to add the milk froth. The recommended milk and coffee ratio for preparing cappuccino coffee is 1/3 espresso, 1/3 warm milk and 1/3 milk froth. To prepare caffè latte, use 1/2 espresso, 2/3 warm milk and approximately 1 cm of milk froth.

5.6 After removing the sleeve **A14**, the nozzle **A15** may be used in the same way to heat water for tea, hot chocolate, etc. When heating water, submerge the nozzle **A15** at least 5 cm under the water level.

5.7 After using the hot steam release function, it is necessary to drain the remaining water from the boiler **A13**; this will prevent the subsequently brewed coffee from being steamed with water that is too hot. Press the button **A5** to the coffee brewing position, underneath the portafilter **A8**, place a cup into which the hot water will be drained, and set the knob **A12** to the coffee brewing position. Wait until the indicator **A6** turns off. Then set the knob **A12** back to the stand-by mode position. The boiler **A13** will heat the new batch of water up to the optimal coffee brewing temperature. This is signalled by the indicator **A6** being lit.

5.8 When you have finished using it, clean out the nozzle **A15** and the sleeve **A14** according to the instructions in chapter Cleaning and maintenance.

6. TURNING OFF THE APPLIANCE

6.1 When you have finished using the appliance, turn it off by pressing and holding down button **A3** for 3 seconds.



Note:

The appliance will turn off automatically after 25 minutes of inactivity or after continuous use of the steam nozzle, or when the pump runs non-stop for 3 minutes in the coffee brewing mode.

BASIC GUIDELINES AND RECOMMENDATIONS FOR BREWING QUALITY COFFEE

- Always brew coffee in a clean espresso machine. A dirty appliance can negatively impact the taste of the coffee beverage. Instructions for cleaning and removing limescale deposits are found in chapter Cleaning and maintenance.
- For brewing quality coffee, it is necessary to use fresh drinking water. Do not use warm, heated, distilled, mineral or sparkling water. Do not leave water in the water tank **A9** for longer than one day.
- Brew coffee from pre-ground coffee that is intended for espresso machines or using freshly ground coffee beans. When using ground coffee beans, it is important to correctly set the grinding fineness. Coffee beans need to be ground to a fine texture but not too fine. If the ground coffee feels like fine flour when sifted between the fingers then the coffee will be brewed for too long and the resulting beverage will be too dark and bitter, or the filter may become clogged. If the coffee beans are ground too coarsely, the brewing process will be too fast and the resulting beverage will have a watery taste and bland aroma.
- Select coffee beans, among others according to the roasting date marked on the package. We recommend consuming freshly roasted coffee beans within 3 weeks of the roasting date. To shorten the storage time, purchase it in smaller packages. Store it in a cool, dark and dry location, ideally in an air-tight container.
- When using pre-ground coffee, store it in an enclosed container, in dry and cool conditions. Do not place it in a refrigerator or freezer. Consume within a week of opening it.

CLEANING AND MAINTENANCE

- Prior to cleaning the appliance, press and hold down button **A3** for 3 seconds, disconnect it from the power socket and allow it to cool down.
- For cleaning, do not use cleaning products with an abrasive effect, solvents, etc. that could damage the appliance. No part of this appliance is intended for washing in a dishwasher.

CLEANING THE FILTERS, PORTAFILTER AND BREW HEAD

- Release the portafilter **A8** by turning the handle to the left. Remove it from the brew head **A7** and move it above a rubbish bin. Turn the portafilter **A8** so that the filter with used coffee grounds points downwards. Use a teaspoon to remove the coffee grounds. Avoid coming into contact with the surface of the filter or portafilter **A8** as they may still be hot. Prior to removing the filter from the portafilter **A8**, cool it down under cold running water. Then rinse the filter and the portafilter **A8** under clean running water and dry them thoroughly.
- If you used coffee that was ground too finely, then the holes in the filter may have become clogged. To clean them out, use a thin needle.
- Remove ground coffee remains from the brew head **A7** using a damp wiping cloth.



Attention:

The brew head **A7** remains hot after use due to residual heat. Allow it to cool down before cleaning it.

CLEANING THE DRIP TRAY

- The drip tray **A11** needs to be emptied and washed every time the appliance is used.
- First remove the grate **A10** from the drip tray **A11** and then remove the water. Wash the drip tray **A11** and the grate **A10** in warm water with neutral kitchen detergent. Then rinse both parts under running water, wipe dry and return to their place.

CLEANING THE NOZZLE AND THE MILK FROTHING ATTACHMENT

- It is necessary to thoroughly clean the nozzle **A15** and the sleeve **A14** after every use.
- Take off the sleeve **A14**, rinse under hot running water and wipe dry.
- Thoroughly clean the nozzle **A15** using a dampened cloth. In the event that there are dried milk residues on the nozzle **A15**, submerge it into a container with hot water to allow them to soak away. In the event that the dried milk residues clog the steam exhaust outlet, clean it out using a needle. Finally, clean the nozzle **A15** using a dampened cloth, wipe dry and install it on to the sleeve **A14**.

CLEANING THE OUTER CASE

- Wipe the outer surface of the appliance using a lightly dampened cloth and wipe dry.

REMOVING LIMESCALE DEPOSITS

- It is necessary to regularly remove limescale deposits from the appliance. Limescale deposits may negatively affect the quality of the brewed coffee and the lifetime of the appliance.
- In the case of daily use of the appliance, we recommended to remove the limescale deposits:
 - once per month in areas with hard and very hard water;
 - once every 2 to 3 months in areas with soft and medium soft water.
- To remove limescale deposits, use a solution of 8% white vinegar and water (recommended dilution ratio of 1:2). Instead of the water and vinegar solution, it is possible to use citric acid or a limescale remover intended for espresso type machines. The recommended dosage for citric acid is 2 teaspoons per 0.5l of water. Dose the limescale remover according to the manufacturer's instructions.
- Fill the water tank **A9** with the solution all the way up to the maximum level line. Connect the appliance to a power socket. Attach the portafilter **A8** to the brew head **A7**. Place a sufficiently large container under the brew head **A7** and the nozzle **A15**. Allow the majority of the solution to flow through the brew head **A7** and allow the remainder to flow through the nozzle **A15**.
- After using the solution, thoroughly rinse out the water tank **A9** using clean water and allow clean water to flow through the appliance once or twice.



Attention:

Do not forget to regularly check the water level in the water tank **A9** and in the drip tray **A11**.

TECHNICAL SPECIFICATIONS

Rated voltage range.....	220–240 V
Rated frequency.....	50 Hz
Rated power input.....	1 050 W
Noise level	75 dB(A)

The declared noise emission level of the appliance is 75 dB(A), which represents a level A of acoustic power with respect to a reference acoustic power of 1 pW.

We reserve the right to change text and technical specifications.

INSTRUCTIONS AND INFORMATION REGARDING THE DISPOSAL OF USED PACKAGING MATERIALS

Dispose of used packaging material at a site designated for waste in your municipality.

DISPOSAL OF USED ELECTRICAL AND ELECTRONIC EQUIPMENT



This symbol on products or original documents means that used electric or electronic products must not be added to ordinary municipal waste. For proper disposal, renewal and recycling hand over these appliances to determined collection points. Alternatively, in some European Union states or other European countries you may return your appliances to the local retailer when buying an equivalent new appliance.

Correct disposal of this product helps save valuable natural resources and prevents potential negative effects on the environment and human health, which could result from improper waste disposal. Ask your local authorities or collection facility for more details.

In accordance with national regulations penalties may be imposed for the incorrect disposal of this type of waste.

For business entities in European Union states

If you want to dispose of electric or electronic appliances, ask your retailer or supplier for the necessary information.

Disposal in other countries outside the European Union

This symbol is valid in the European Union. If you wish to dispose of this product, request the necessary information about the correct disposal method from the local council or from your retailer.



This product meets all the basic requirements of EU directives related to it.